

Shown below is a schematic for connecting additional [R-932/R-934](#) stages. This technique would apply if connecting two CM-024's, CM-024 to a CM-026 or a CM-027, or a CM-024 to a CM-025 as shown.

**1** The supply into the "supply port" on the CM-024 through the jumper line provides supply to the additional [R-932](#) stage board.

Port 5 on the first CM-024 board and the last additional [R-932](#) must be plugged, (Use Clippard P/N [11755](#) screw plug.)

**3** The output of valve 7 on the CM-025 is connected to port 6 on the CM-024. The purpose is to establish the next cycle. The connection from the end port on the additional stage [R-932](#) / [R-934](#) connects to port 4 of that board. This provides pressure to port 6 of CM-024 when valve 7 of CM-025 shifts to the "output" mode. (This is the last step in the cycle.)

Modification of circuits can be easily accomplished by changing the input/output sequence. Refer to the Clippard Designer's Guide for additional information on this unusual and easy to use pneumatic control circuit sequence system.

## CM-024

5-Valve Sequence Circuit Board used as the Starter Subplate

Size: 9 1/2" x 2 1/2" x 13/16" thick - 5 modules

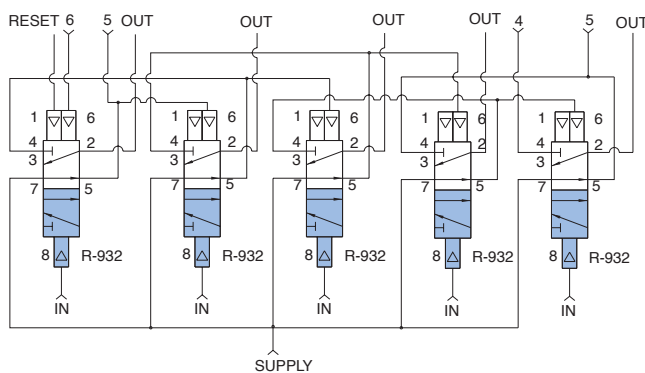

**Operation:** This five valve sequence circuit board is used as the starter; #10-32 port connections provided for signal inputs, step outputs, reset input, and jumper connections for linking multiple boards together. May be linked to CM-024, -025, -026, -027, or -035 or any combination thereof to achieve sequential steps. 1/8" NPT port provided for incoming supply with #10-32 port provided for linking supply to downstream expander units. In addition, step-by-step input requirements make integration of this manifold, with various others shown in the catalog, quick and easy for development of complex control circuitry.

**Use:** The [R-932](#) sequence control circuit board is a compact efficient system for integrating sequential control of a multi-step operation. It has many uses throughout industry. For example:

- Metalworking: multiple drilling, tapping, etc. Operation where workpiece must be clamped, worked, released, and transferred in a precise order with no overlapping steps.
- Production: where a unit is sized, wrapped, and cut in proper sequence.
- Assembly: insertion of product in package, closure, and delivery to a conveyor. The CM-024 may be linked to CM-025, -026, -027, or -035 as required to provide additional sequence steps.

**Note:** Output of last step must be connected to port 6.

